



Drainage pumps with “Double-Channel” impeller for pumping waste waters and liquids with suspended solids; ideal for civil and household applications. The single-phase version includes a built-in capacitor, a thermal protector and it can be equipped with a float switch.



## Construction features

**Pump body** cast iron

**Shell, motor cover, base support** stainless steel



**Impeller** stainless steel

**Mechanical seal** double seal with oilchamber: silicon carbide on pump side, ceramic-graphite on motor side

**Motor shaft** stainless steel AISI 430

**Free passage** Ø max 50 mm

**Max submergence** 5 m

**Liquid temperature** 0 - 40 °C

**Cable** H07 RN8F, 10 m

**G** float switch

## Motor

3~ 380V - 60Hz

**2 Poles induction motor** 1~ 220V - 60Hz  
(with thermal protection)

**Insulation class** F

**Protection degree** IPX8

TYPE	LOTS			
	TRUCK		CONTAINER	
	PALLET (cm)	N° pumps	PALLET (cm)	N° pumps
DB	80×120×160	51	80×120×160	51

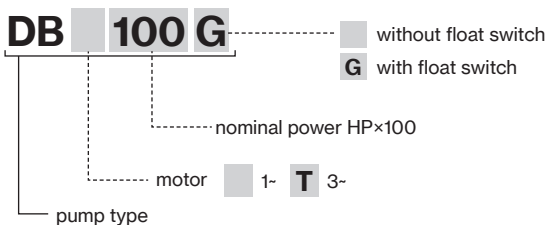

# DB

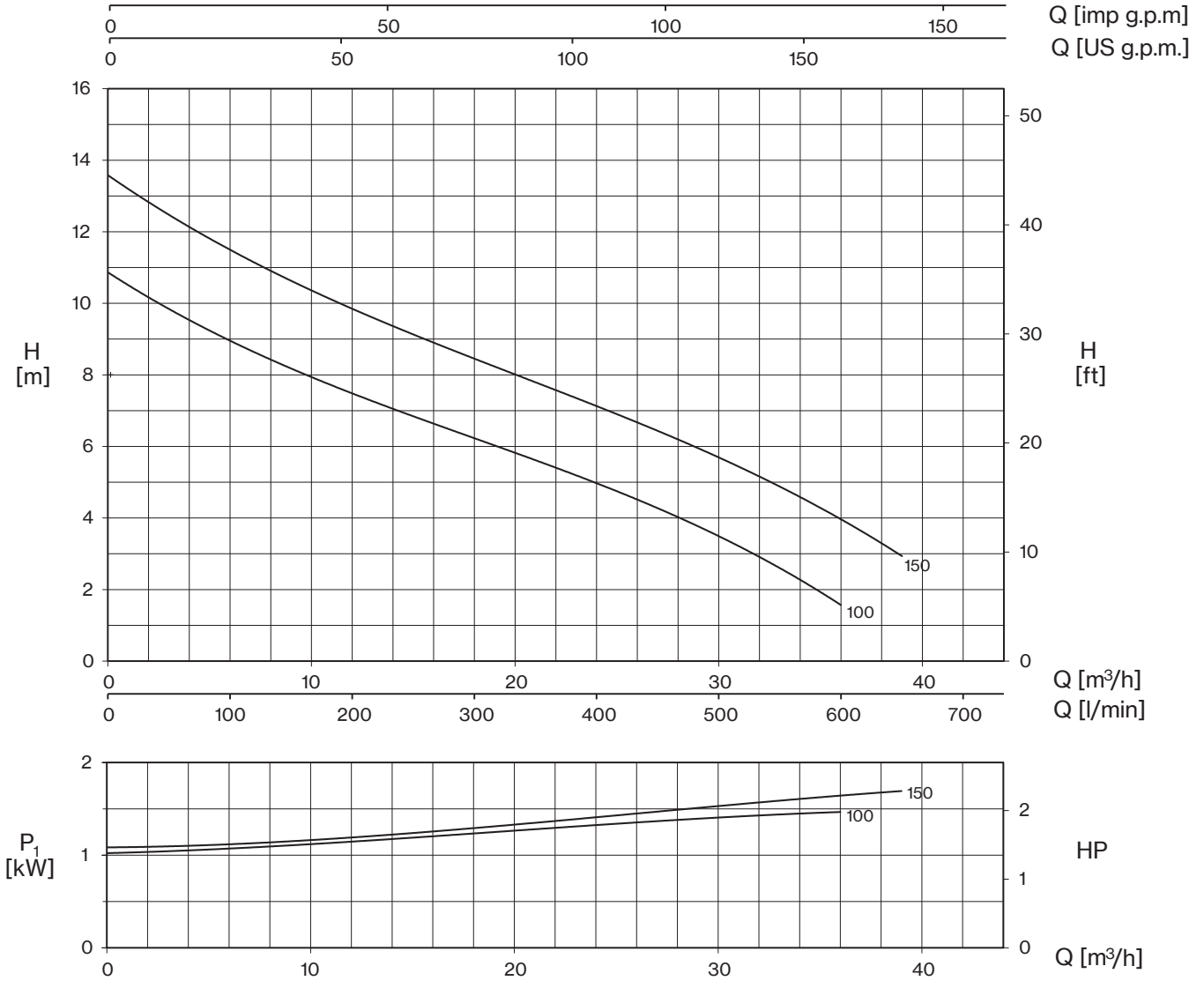

TYPE		W	AMPERE		Q (m <sup>3</sup> /h - l/min)							
1~	3~		1~ 1x220 V 60 Hz	3~ 3x380 V 60 Hz	0	6	12	18	24	30	36	39
					0	100	200	300	400	500	600	650
					H (m)							
DB 100 (G)	DBT 100	1440	6,9	3,1	10,9	9,0	7,4	6,2	5,2	3,3	1,6	
DB 150 (G)	DBT 150	1720	8,7	3,3	13,6	11,4	9,8	8,6	7,2	5,6	3,9	3,0

E: maximum emptying level  
Mt: minimum liquid level for continuous duty

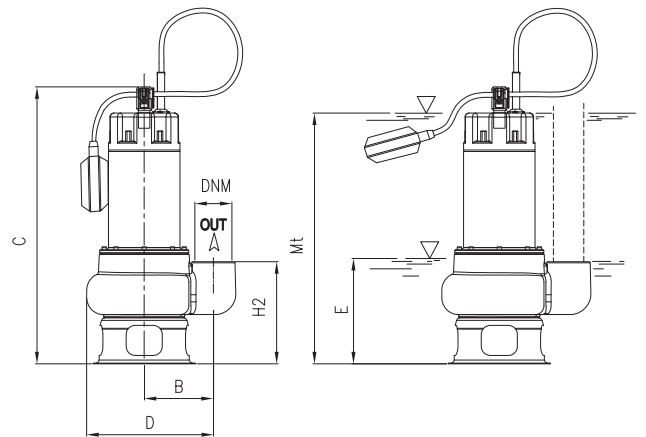

TYPE	DIMENSIONS (mm)										Kg
	B	C	D	E	H2	Mt	DNM	I	L	M	
DB 100 (G)	142,5	461	247,5	185	170	390	2" G	200	260	470	17
DB 150 (G)	142,5	461	247,5	185	170	390	2" G	200	260	470	18,5

